

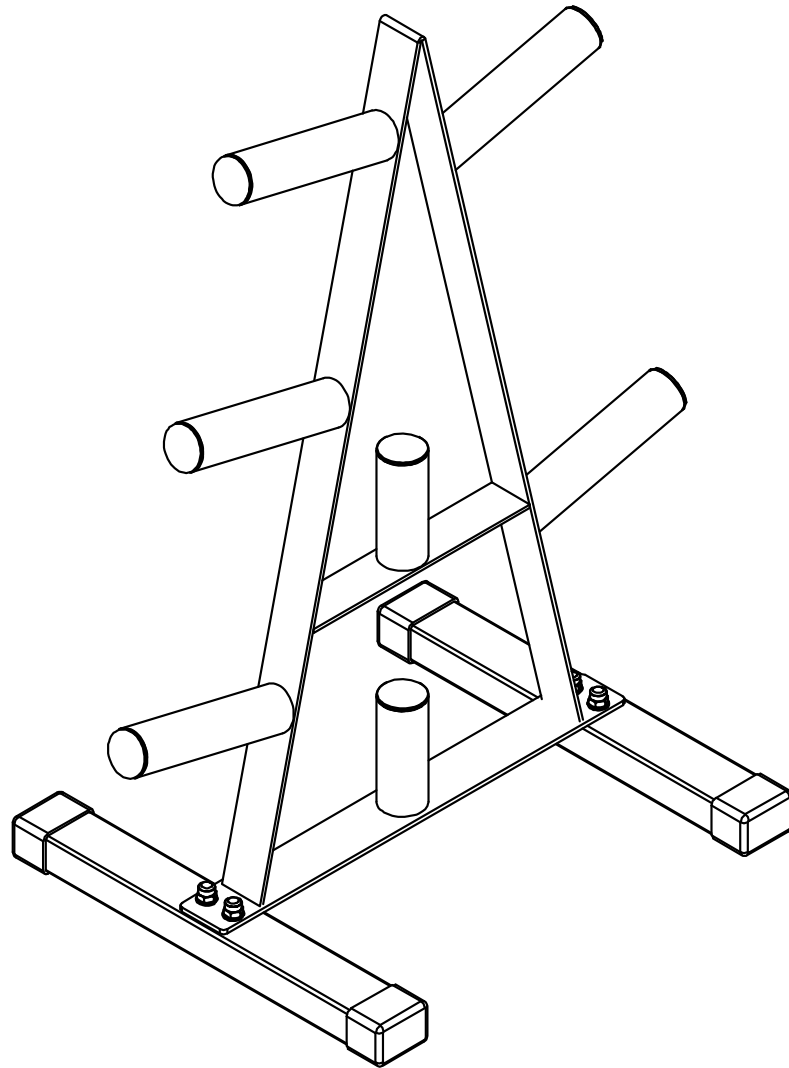

**2" PLATE RACK
B07DQ9MSDC/D1BPR500**

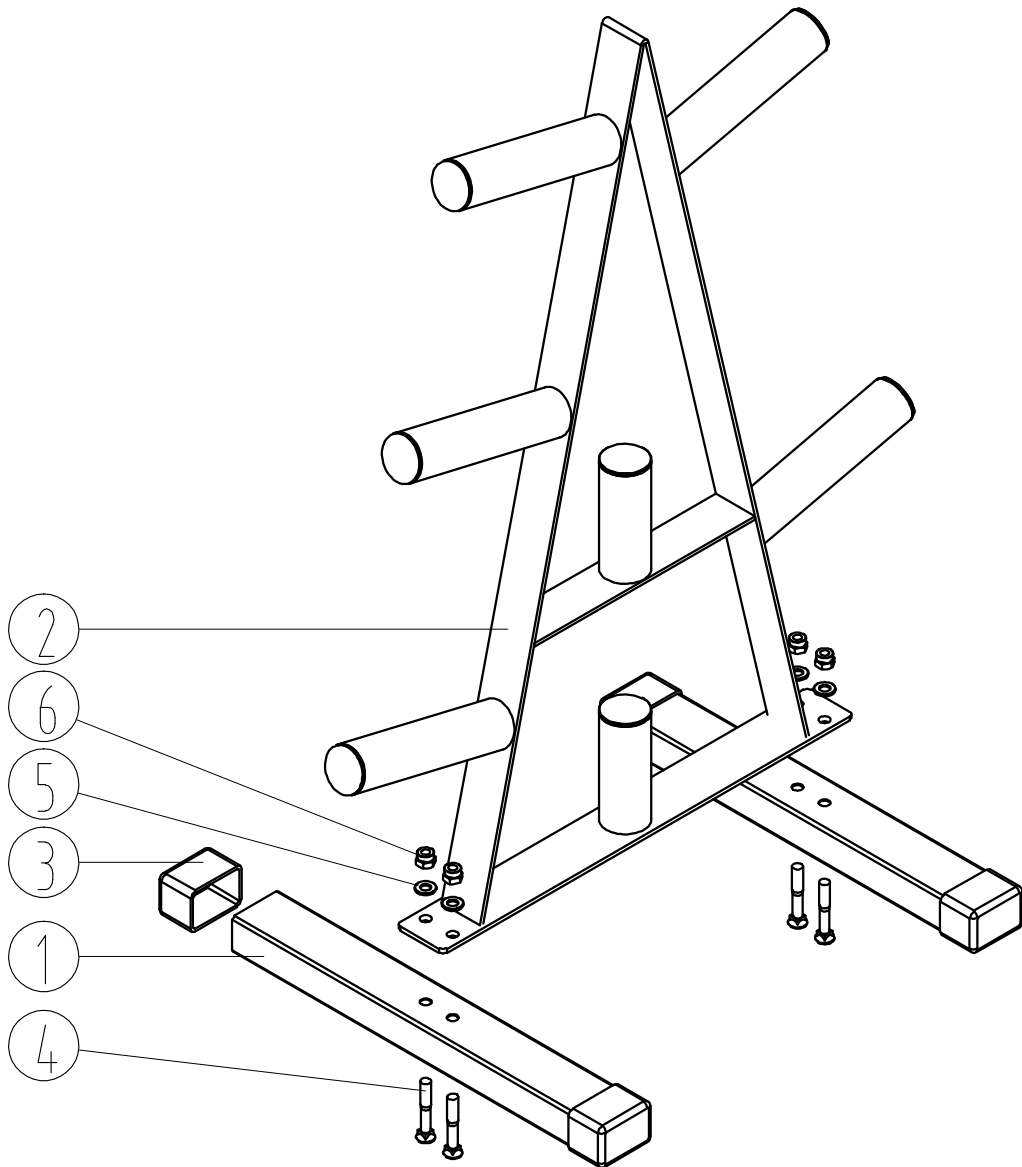



| NUMBER | DESCRIPTION | QUANTITY | NUMBER | DESCRIPTION | QUANTITY |
|--------|-------------|----------|--------|--------------------------|----------|
| 1 | Base foot | 2 | 4 | Square neck screw M10*45 | 4 |
| 2 | Main frame | 1 | 5 | WASHER 10 | 4 |
| 3 | Foot set | 4 | 6 | LOCK NUT M10 | 4 |

Exploded drawing:

1. Attach Set foot 3 to base foot (1) on both feet

2. Insert Square neck screw (4) into both base feet from the bottom up through the holes. Place Main frame (2) and align holes with top of the screws so that screws come up through the holes on the main frame.

3. Place washers (5) onto the screws and add Lock Nuts (6) and tighten down when both sides are complete